

ITEM NO.	PART NUMBER	DESCRIPTION	QTY.
1	FAIRLEAD MOUNT TOP		1
2	FAIRLEAD MOUNT BOTTOM		1
3	90185A591	5/16 X 2 CARRIAGE BOLT	2
4	90185A583	5/16 X 1 CARRIAGE BOLT	2
5	97135A220	5/16 LOCK NUT	4
6	90126A030	5/16 WASHER	4

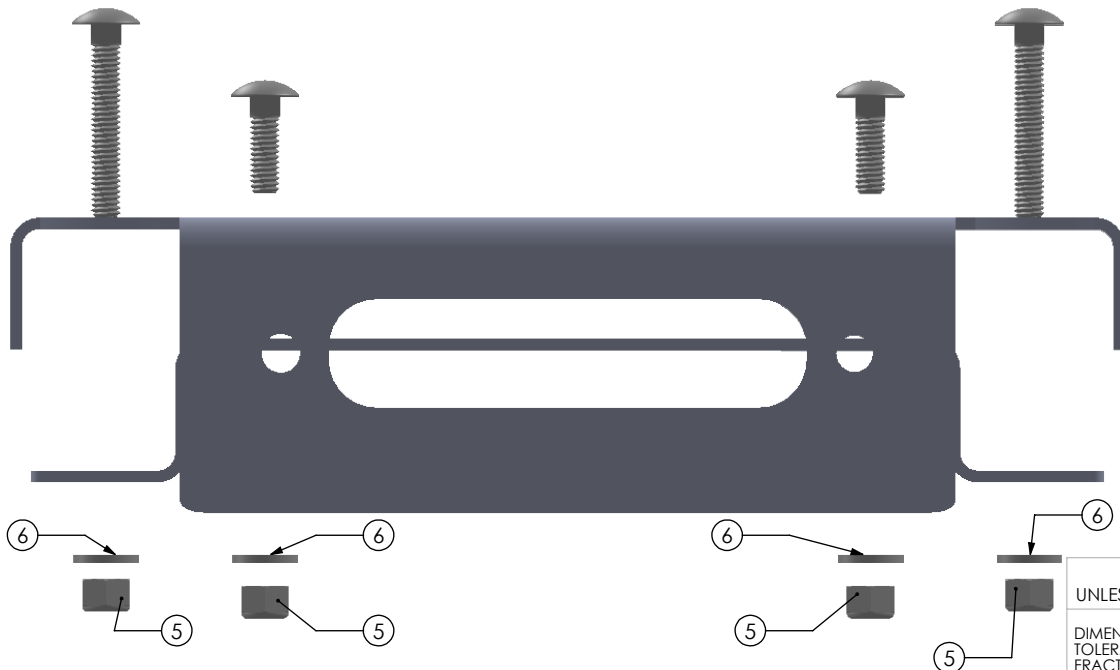
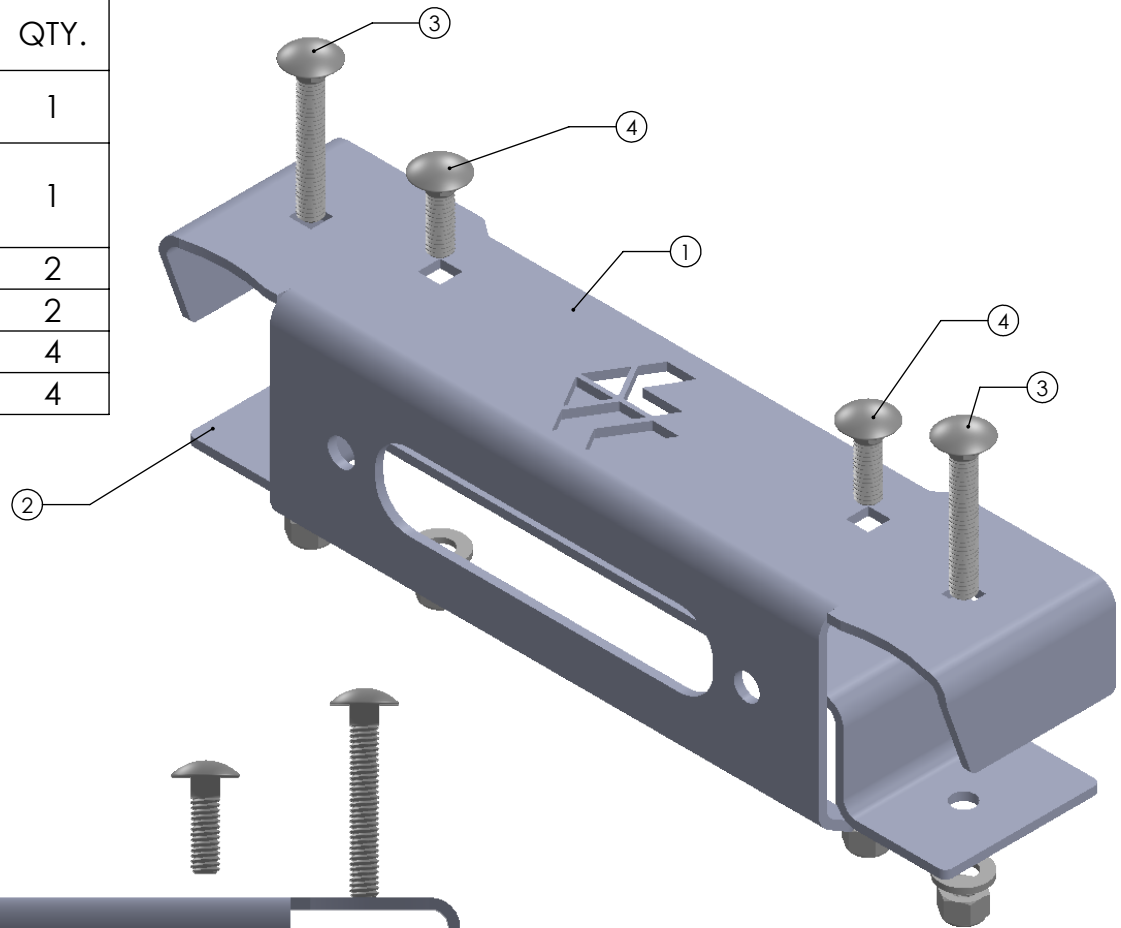

**MOUNTS SANDWICH THE FACTORY BUMPER.
PLACE THE MOUNT AS FAR FORWARD ON THE BUMPER
AS POSSIBLE AND TIGHTEN THE (2) 5/16 X 1" BOLTS.**

**USING A 5/16 DRILL, DRILL THROUGH THE FACTORY BUMPER
AND PLACE THE (2) 5/16 X 2" BOLTS THROUGH AND TIGHTEN
DOWN**

UNLESS OTHERWISE SPECIFIED:

DIMENSIONS ARE IN INCHES
TOLERANCES:
FRACTIONAL: $\pm 1/16$
ANGULAR: MACH ± 1 . BEND $\pm .5$
TWO PLACE DECIMAL: $\pm .01$
THREE PLACE DECIMAL: $\pm .005$



DRAWN: CHET G.

TITLE:

TALON FAIRLEAD MOUNT

MATERIAL

SCALE: 1:5

WEIGHT:

SHEET 1 OF 1